



Cortavientos



Características y aplicaciones



Sistema complementario para toldos planos como cerramiento y todas las utilidades de un toldo vertical.

Se compone de un perfil-guía en U y un perfil de carga con un pestillo, el perfil-guía lleva una cinta guarda polvo para evitar el roce entre los dos perfiles.

También puede montar el perfil intermedio que le da rigidez.

Las medidas máximas del producto son 4m de línea por 3m de salida.

Characteristics and applications



System to complement flat awning systems. It provides enclosure of the space and provides all the utilities of a vertical awning.

Made up of a U shaped guide-profile and a load profile with a clip.. The guide-profile has a dust cover strip to prevent friction between both profiles.

An intermediate profile can also be assembled to provide extra rigidity.

The maximum dimensions are 4m line by 3m projection.

Caractéristiques et les usages



Système complémentaire pour fermeture de pergolas et présentant tous les avantages d'un store vertical.

Il est composé d'un profilé-rail de guidage en U et d'une barre de charge avec loquet, le profilé-rail de guidage comporte une bande pare-poussière pour éviter le frottement entre les deux profilés.

On peut également monter le profilé intermédiaire qui donne de la rigidité.

Les mesures maximales du produit sont 4m de largeur sur 3m d'avancée.

Eigenschaften und Anwendungen



Zusätzliches System für die Abdeckung bei Flachmarkisen und allen Verwendungsmöglichkeiten einer vertikalen Markise.

Es besteht aus einer U-Führung und einem Ladeprofil mit Riegel. Die Führung hat einen Überzug, der die Reibung zwischen den zwei Profilen vermeidet.

Man kann auch das Zwischenprofil montieren, um mehr Straffheit zu erreichen.

Die Höchstmaße des Produkts sind 4 m Breite und 3 m Ausladung.

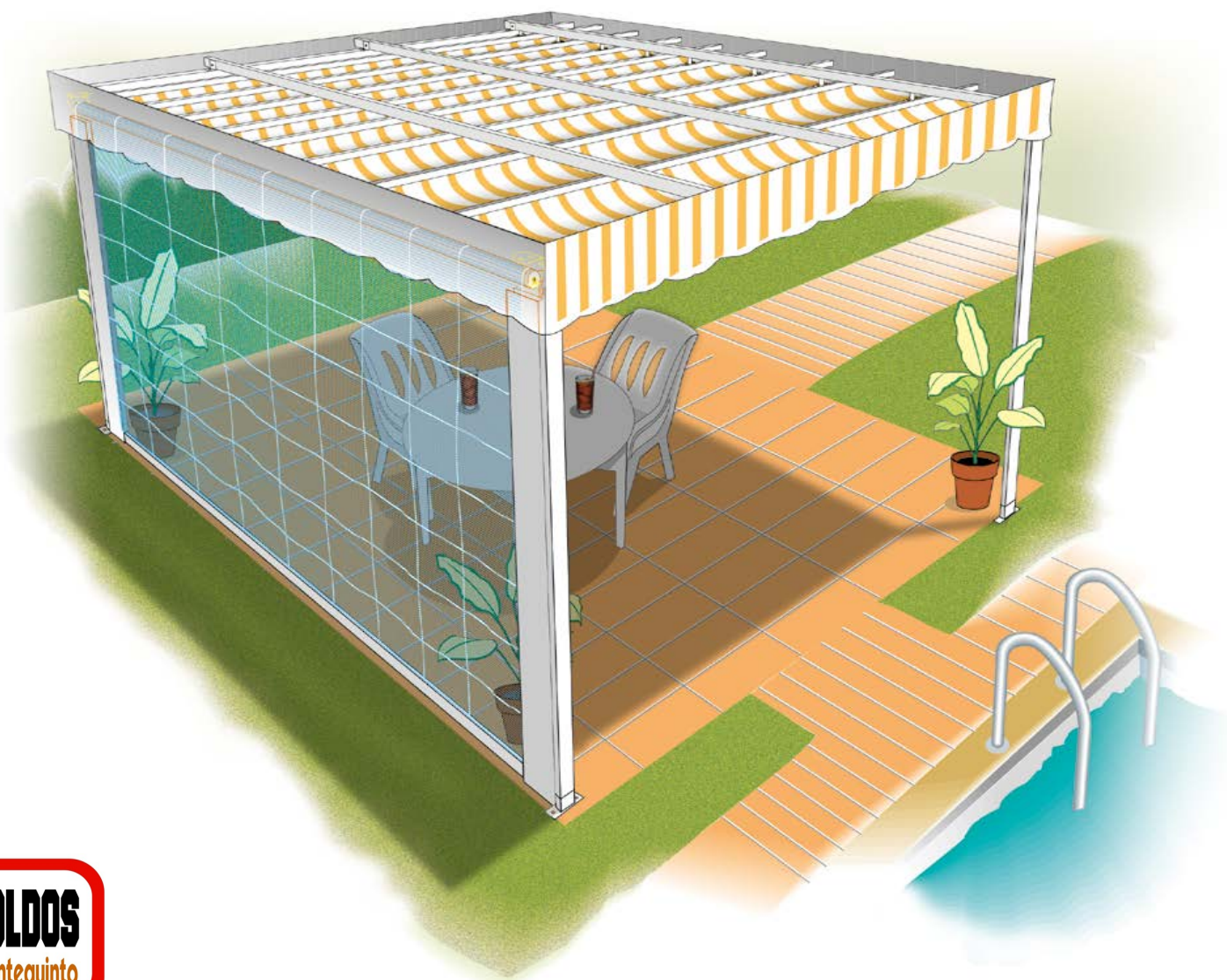

Cortavientos

Despiece -

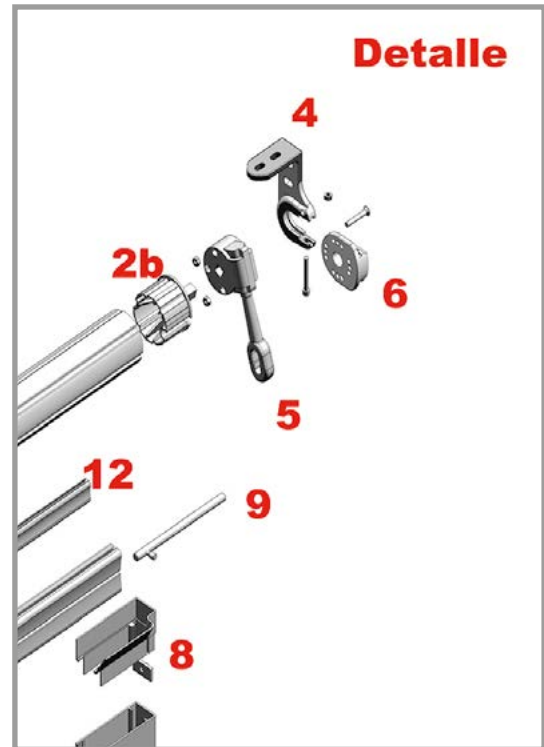
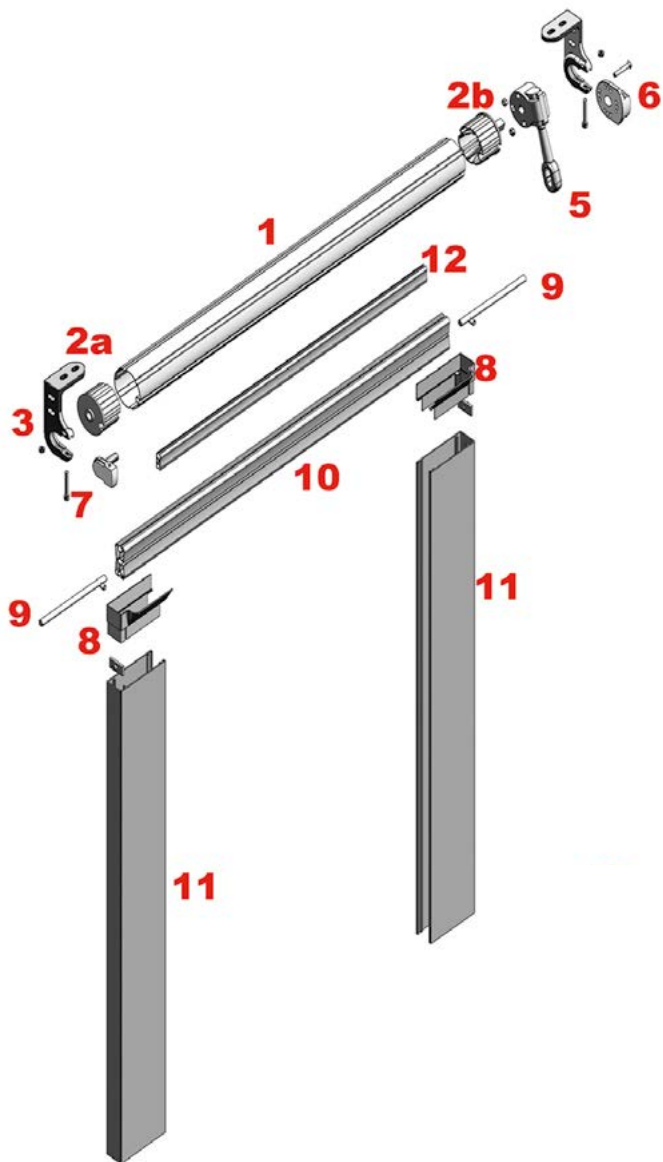

Protección Solar y Cerramientos



- 1: Tubo de enrollle
- 2a: Casquillo sin punta
- 2b: Casquillo máquina
- 3: Soporte almagro izquierdo
- 4: Soporte almagro derecho
- 5: Máquina
- 6: Acople máquina
- 7: Acople punta
- 8: Embudo
- 9: Pestillo
- 10: Perfil carga cortavientos
- 11: Perfil guía cortavientos
- 12: Perfil intermedio cortavientos



- 1: Roller tube
- 2a: Valve holder without point
- 2b: Machine valve holder
- 3: Left Almagro support
- 4: Right Almagro support
- 5: Machine
- 6: Machine coupling
- 7: Point coupling
- 8: Funnel
- 9: Clip
- 10: Windbreak load profile
- 11: Windbreak guide profile
- 12: Windbreak intermediate profile



- 1: Tube d'enroulement
- 2a: Embout sans pointe
- 2b: Embout côté treuil
- 3: Support Almagro gauche
- 4: Support Almagro droit
- 5: Treuil
- 6: Raccord treuil
- 7: Raccord côté opposé au treuil
- 8: Embout
- 9: Loquet
- 10: Barre de Charge Coupe-vent
- 11: Profil é Rail de guidage Coupe-vent
- 12: Profilé Intermédiaire Coupe-vent



- 1: Tuchwalze
- 2a: Buchse ohne Stift
- 2b: Maschinenbuchse
- 3: Linke Almagrohalterung
- 4: Rechte Almagrohalterung
- 5: Getriebe
- 6: Ankopplung Getriebe
- 7: Stiftankopplung
- 8: Trichter
- 9: Riegel
- 10: Windschutz-Ladeprofil
- 11: Profil Windschutzführung
- 12: Windschutzzwischenprofil



Juego Soportes Almagro



Juego Embudos Guía Cortavientos

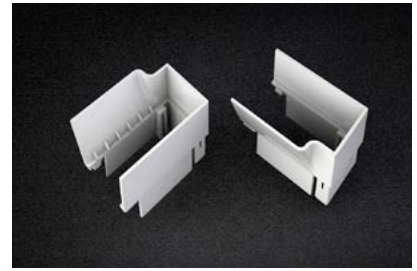

Juego Embudos 70x40 Guía Cortavientos



Perfil Guía Cortavientos



Perfil Guía Cortavientos 70x40



Perfil Carga Cortavientos



Perfil Intermedio Cortavientos



Perfil Intermedio Cortavientos PLUS



Tope Cortavientos



Pestillo Cortavientos Inox



Cinta Guardapolvo